

J&D Manufacturing

JDDT1 - Single Stage Digital Thermostat with NTC Style Temperature Probe



The JDDT1 Digital Temperature Switch with NTC Style Temperature Probe combines reliability and an installation friendly weatherproof enclosure. Programming parameters can be quickly completed using the front keys. In order to prevent tampering from unauthorized users, a parameter lock physical jumper and software pass-code security are standard in the unit. The bright, easy-to-read LED display shows the current output status and the temperature measurement.

The multiple conduit knockouts on the JDDT1 give flexibility to the installer to determine the best location for the conduit entry. Another installation friendly feature of the JDDT1 is the ability to quickly jumper the line voltage to the common of the output relay using female disconnects.

RECOMMENDED TOOLS FOR INSTALLATION (NOT PROVIDED)

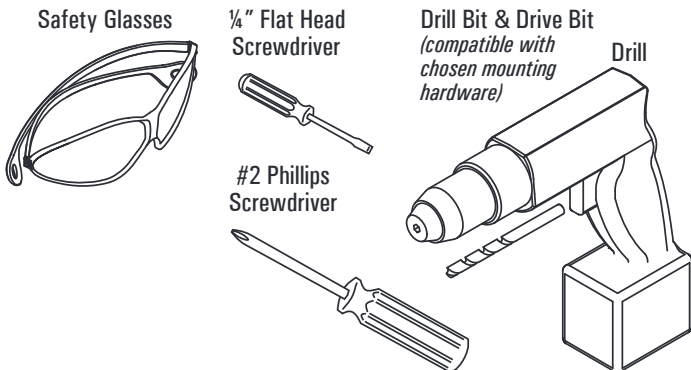

WARRANTY

J&D Mfg. warrants all products are free from defects in materials and workmanship under normal use for the period of one year from date of purchase and our warranty does not cover normal or regular wear and tear. J&D Mfg can repair or replace at our option, any product or part of the product that is found to be defective. Our warranty applies to materials only and does not include return freight, delivery, loss or damage to personal property, cost of removal or installation, any incidental or consequential damages or labor. This warranty does not apply to products which are misused, abused, altered, improperly installed or subject to negligence. All warranties must be approved through our warranty department. The original purchaser must present a copy of the invoice for the defective product. One year is our standard warranty unless specified on our literature or in the installation instructions/user manuals.

PARTS LEGEND

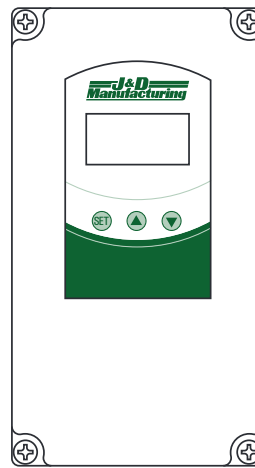

Control

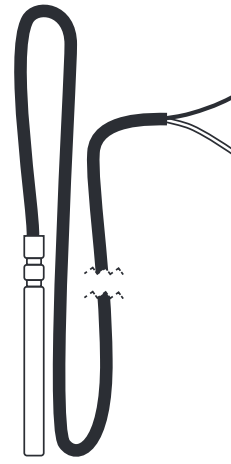

Temperature Probe with 10' Cord



Cord Grip for Temperature Probe Cord

RECOMMENDED (NOT INCLUDED) PARTS

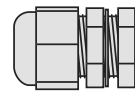

Cord Grip* for Input Power Cord

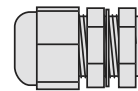

Cord Grip* for Output Power Cord

*To maintain weather proof enclosure status, ALL entering and exiting wiring requires properly sized watertight cord grips (not provided).



2 Female 1/4" Disconnects

For quick jumper option Female Disconnects (not provided) are needed.

INSTALLATION HARDWARE IS NOT PROVIDED

INSTALLATION

Please read over all instructions carefully before you begin. If you have any questions please call your local dealer, or contact J&D Manufacturing at 1-800-998-2398.

SPECIFICATIONS

Probe Range: NTC: -58 to 230°F (-50 to 110°C)

Input: NTC (10KΩ @ 25°C)

Output: R1 SPDT Relay Resistive Load: 20A @ 240 VAC

Horsepower Rating: R1 2HP @ 240 VAC, 1 HP @ 120 VAC

Control Type: On/Off

Power Requirements: 90 to 255 VAC

Power Consumption: 3.6VA

Accuracy: ± 1% FS

Display: 3 digits plus sign

Resolution: .1° < 100°; 1° ≥ 100°

Memory Backup: Non-volatile memory

Ambient Temperature: 32 to 104°F (0 to 40°C)

Weight: 1.2 lbs (544 g)

Front Protection: NEMA 4X (IP66)

Agency Approvals: CE, UL, cUL

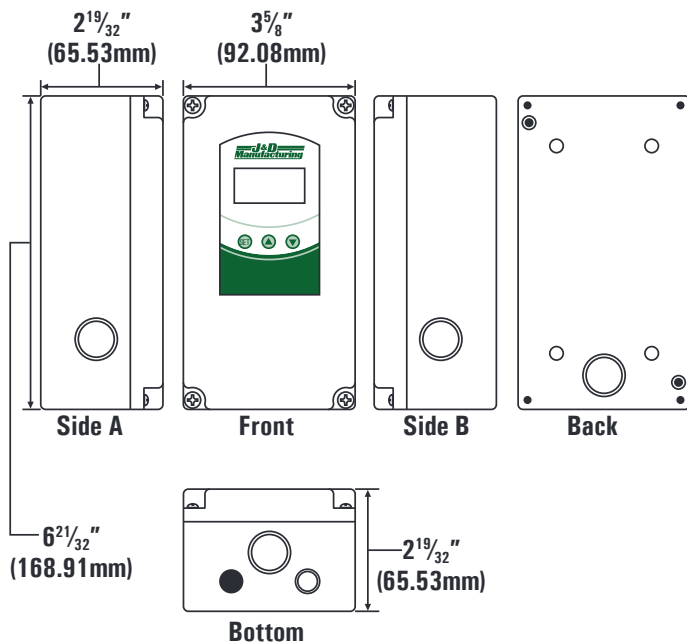

MOUNTING LOCATION REQUIREMENTS

JDDT1 control should be located in a place free of vibrations, impacts, and corrosive gases.

⚠ DISCONNECT POWER ⚠
BEFORE INSTALLING OR SERVICING.

ALL ELECTRICAL WORK SHOULD BE COMPLETED BY QUALIFIED PERSONNEL AND MEET NATIONAL (NEC), REGIONAL AND LOCAL ELECTRIC CODES.

OPENING ENCLOSURE

Using a #2 Phillips Screwdriver, unscrew the 4 screws that secure the control enclosure cover and base together.

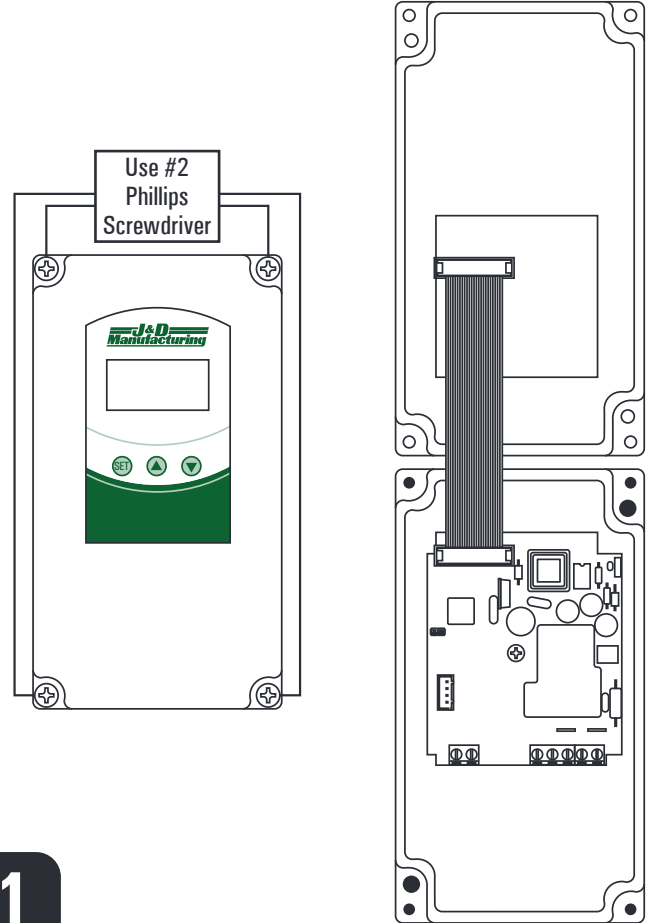

MOUNTING CONTROL

Secure the JDDT1 control to your selected location using the (2) indicated mounting holes and appropriate (not included) hardware.

Mounting hardware must be able to support the weight of the JDDT1, 1.2 lbs (544 g) and be compatible with the mounting surface/structure.

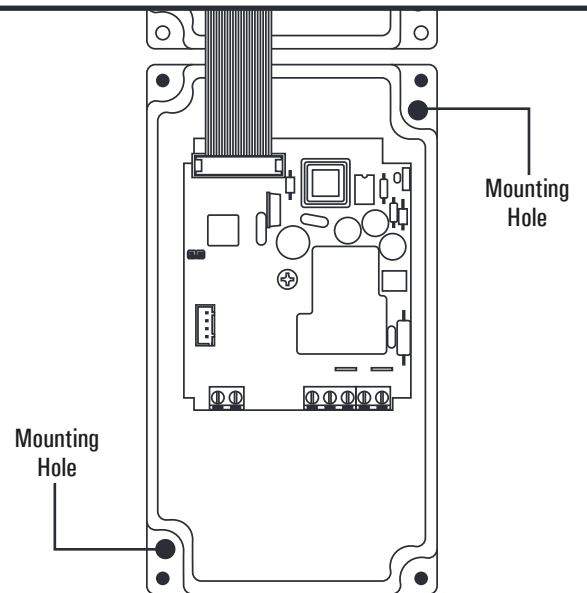

INSTALLING TEMPERATURE PROBE CORD GRIP

Install the included temperature probe cord grip in pre-knocked out location as shown below.

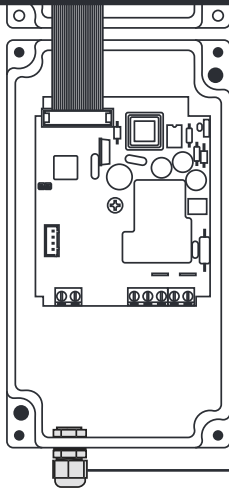

Front View

Temperature Probe Cord Grip

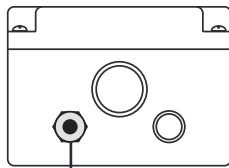

Bottom View

Temperature Probe Cord Grip

2

IDENTIFYING WIRING & PROGRAMMING LOCATIONS

Use the below illustration and call-outs to identify the areas for the future steps of installation.

NOTE: Numbers indicated below and in future steps are to identify the inputs and outputs for ease of installation, the contacts are not labeled in the control.

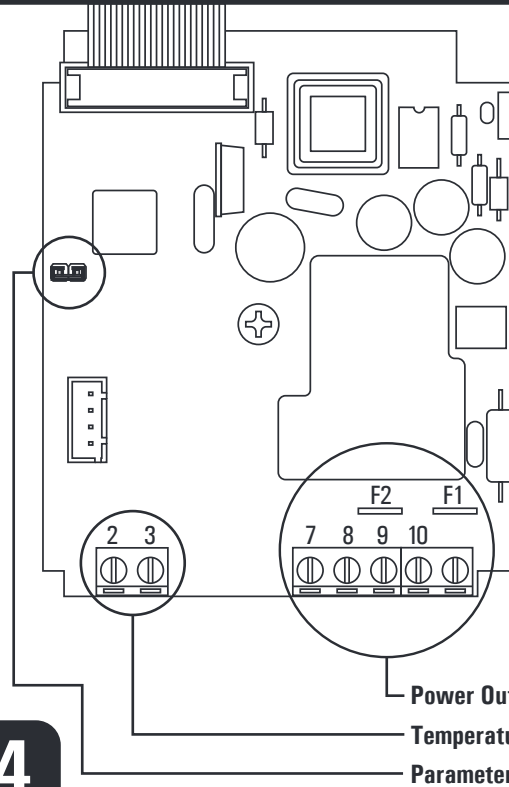

4

INSTALLING (not provided) INPUT & OUTPUT CORD GRIPS

Select and prepare two knockouts one for input and one for output wiring. To maintain weather proof enclosure status, input and output wiring requires properly sized watertight cord grips (not provided).

NOTE: Use knockouts that are appropriate to your needs and location.

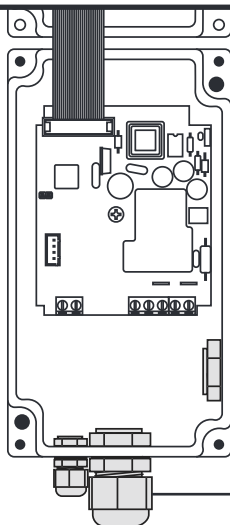

Front View

Properly Sized Cord Grips (not included)

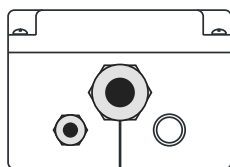

Bottom View

Properly Sized Cord Grips (not included)

3

INSTALLING THE TEMPERATURE PROBE

Thread end of temperature probe through previously installed cord grip. Using a 1/4" Flat Head Screwdriver secure the temperature probe wires to 2 and 3 connector as shown below.

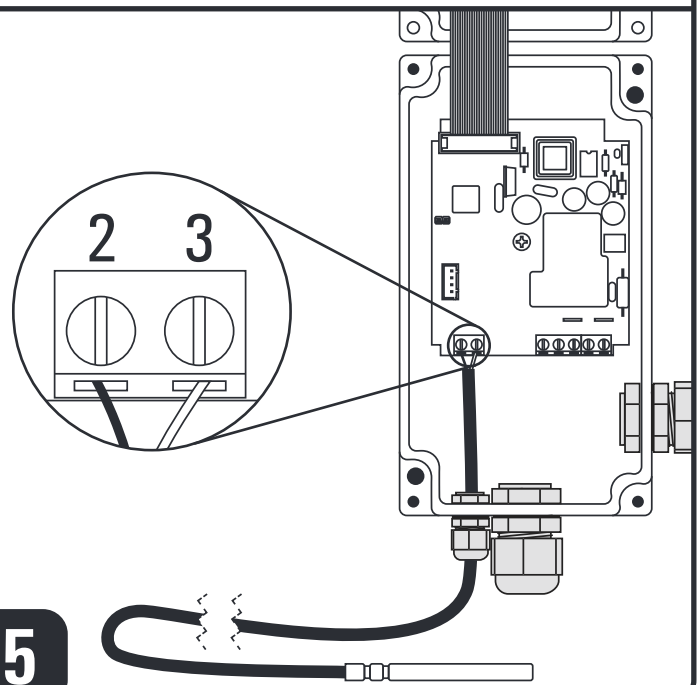

5

If powering unit separate from control, proceed to **Step 6**.

If power for unit is run through control AND input wire is 14 AWG or smaller, proceed to **Step 7**.

If power for unit is run through control AND input wire is 12 AWG or larger, proceed to **Step 8**.

WIRING POWER TO UNIT SEPARATE FROM CONTROL

Thread ends of Line Power Input and Output to Unit through previously installed cord grip. Following the table and illustration below, use a 1/4" Flat Head Screwdriver to secure wires, as shown.

L2 / N (Input Power for Control)	11
L1 (Input Power for Control)	10
L1 (Input Power for Unit)	9
L1 (Output to Unit)	8
L2 / N (Input Power for Unit)	L2 / N (Output to Unit)
Ground (Input)	Ground (Unit)

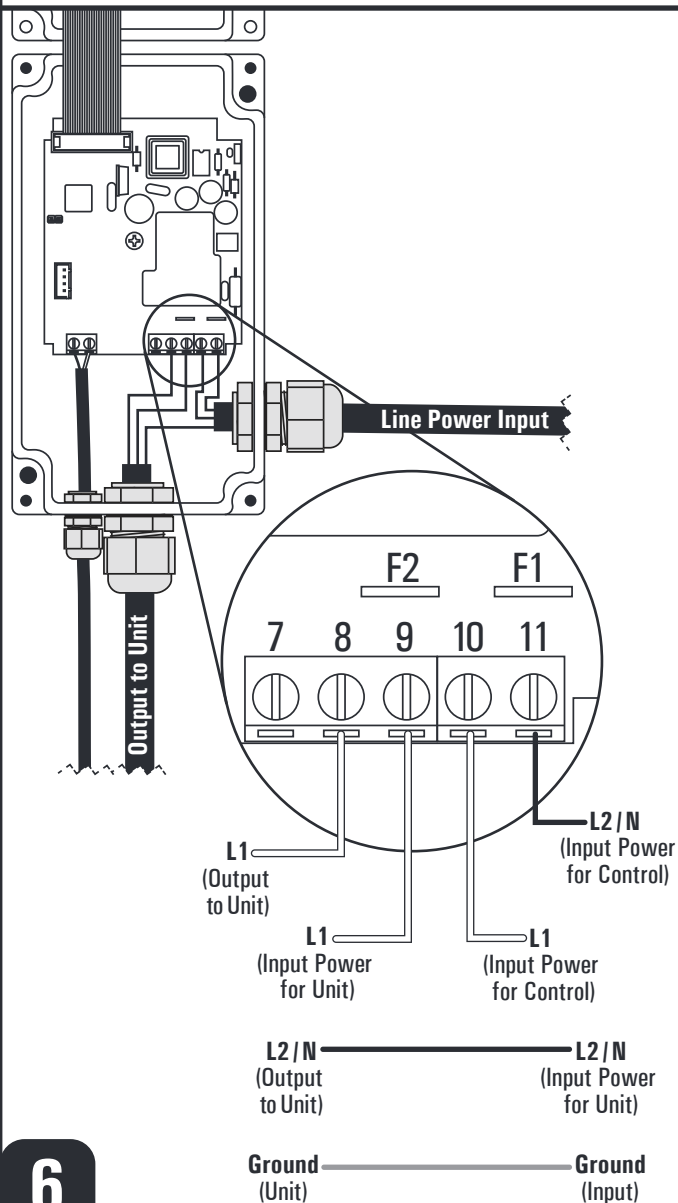

6

Once finished with **Step 6**, proceed to **Step 9**.

WIRING POWER THROUGH CONTROL TO UNIT WITH AN INPUT WIRE OF 14 AWG OR SMALLER

Thread ends of Line Power Input and Output to Unit through previously installed cord grip. Following the table and illustration below, use a 1/4" Flat Head Screwdriver to secure wires, as shown.

L2 / N (Input Power for Control & Unit)	11
L2 / N (Output to Unit)	11
L1 (Input Power for Control & Unit)	10
Jumper	9 to 10
L1 (Output to Unit)	8
Ground (Input)	Ground (Unit)

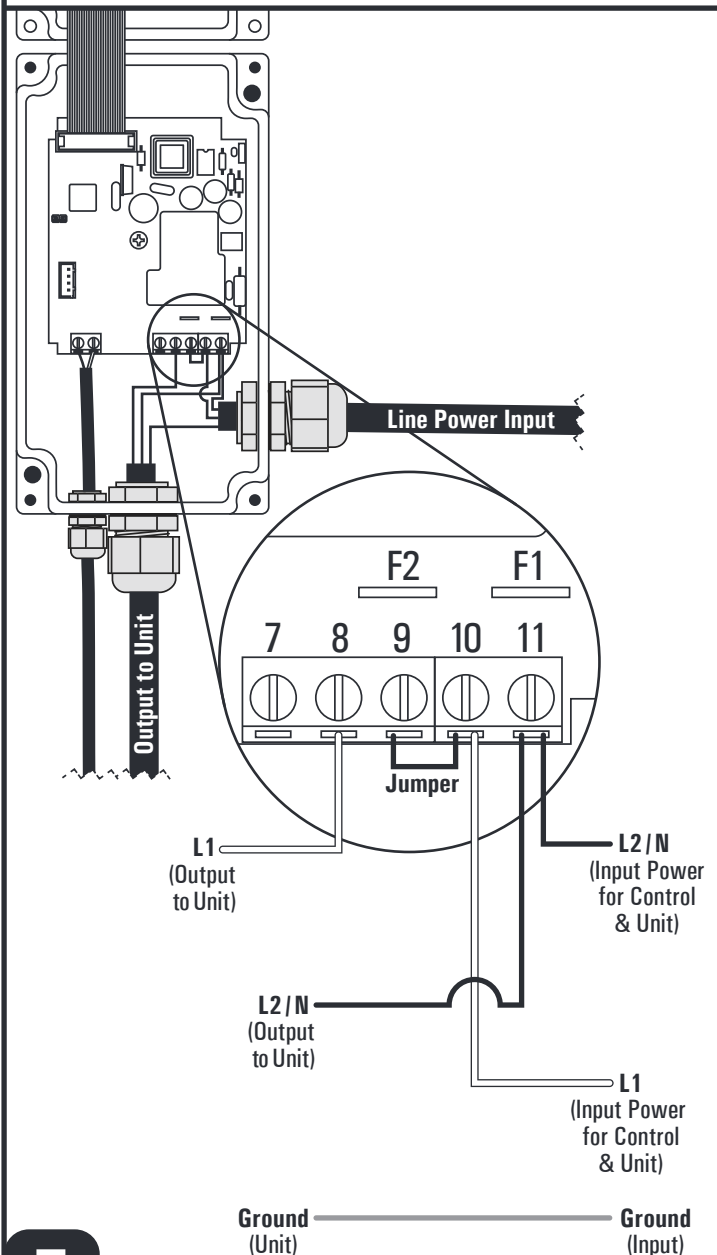

7

Once finished with **Step 7**, proceed to **Step 9**.

WIRING POWER THROUGH CONTROL TO UNIT WITH AN INPUT WIRE OF 12 AWG OR LARGER

Thread ends of Line Power Input and Output to Unit through previously installed cord grip. Following the table and illustration below, use a ¼" Flat Head Screwdriver and (2) Female ¼" Disconnects (not provided) to secure wires, as shown.

L2 / N (Input Power for Control & Unit)	11
L2 / N (Output to Unit)	11
L1 (Input Power for Control & Unit)	10
L1 (Output to Unit)	8
Jumper	F1 to F2
Ground (Input)	Ground (Unit)

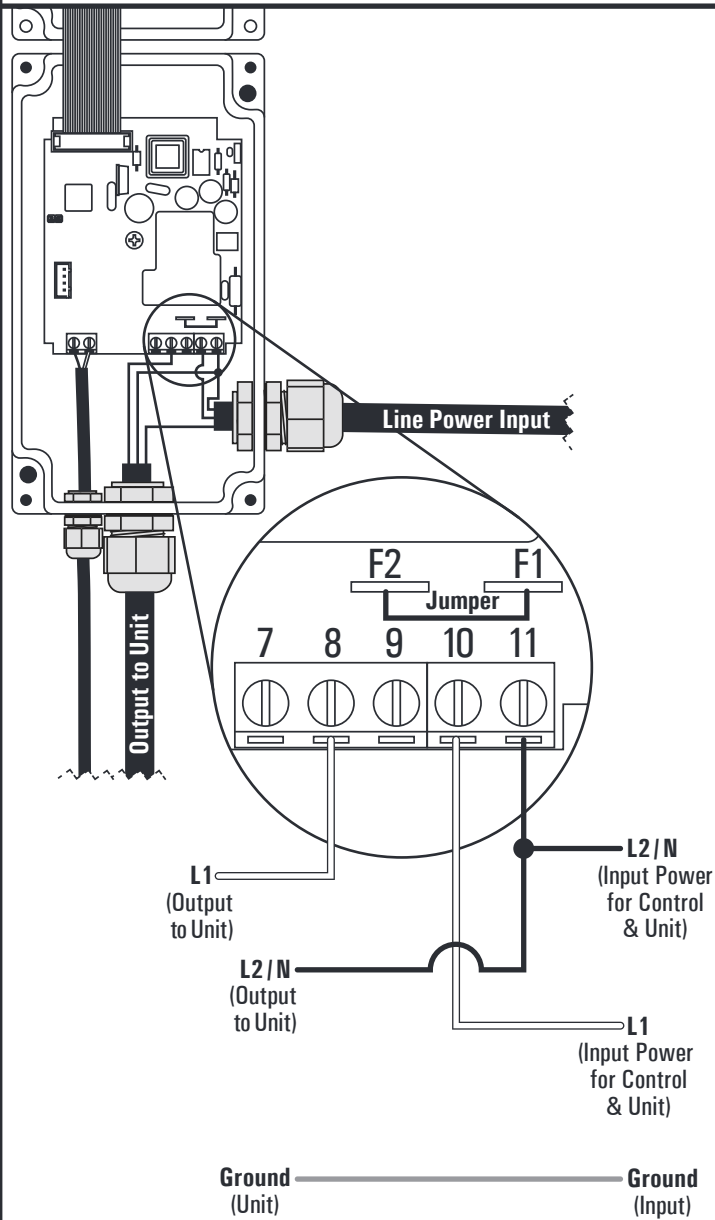

8

UNLOCK CONTROL FOR PROGRAMMING

In order to adjust parameter values, the parameter lock jumper must be set in unlocked position, as shown below.

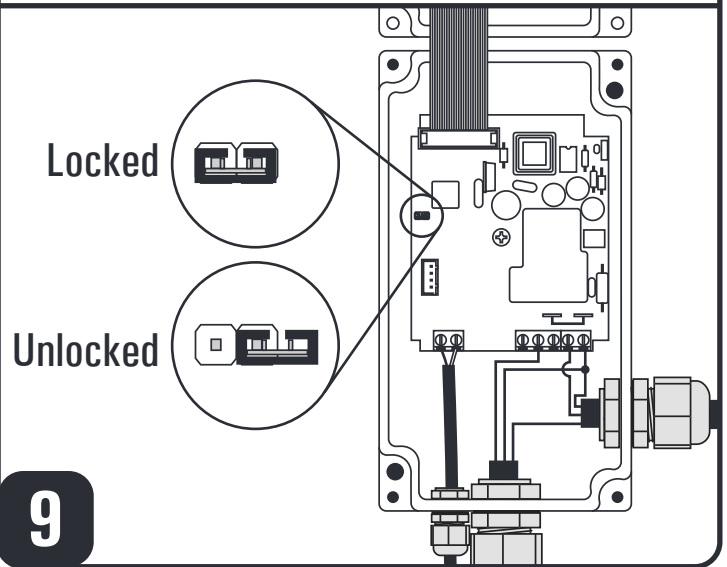

CLOSE ENCLOSURE

Using a #2 Phillips Screwdriver, screw the 4 screws that secure the control enclosure cover and base together.

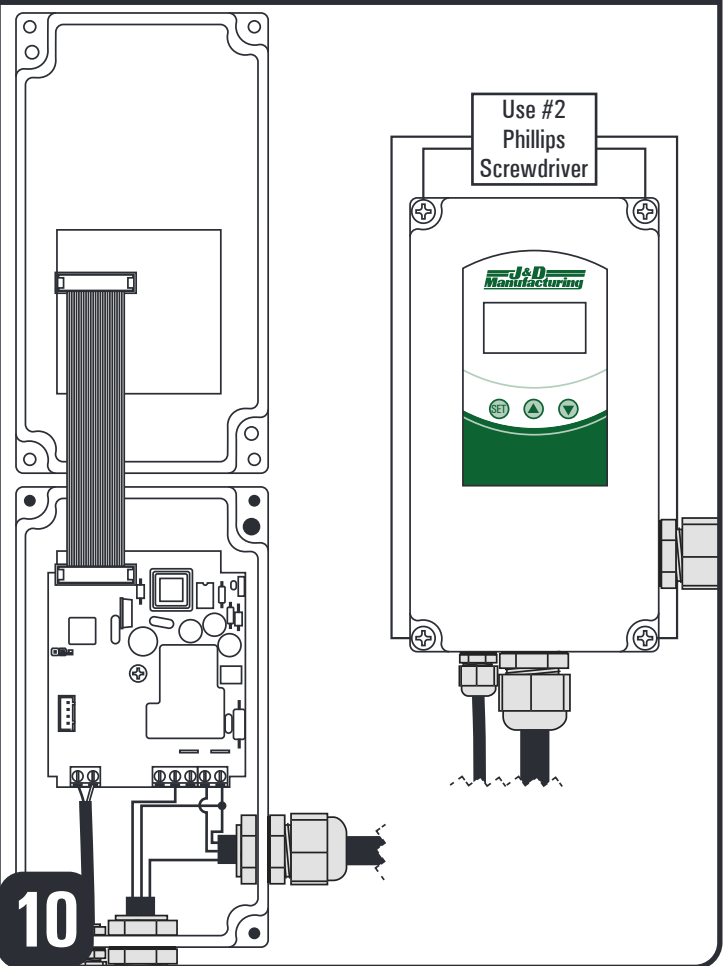

⚠ WARNING ⚠
Provide power to control ONLY when enclosure is closed and cover is secure.

ACCESSING & SECURING PARAMETERS

To allow access (unlock) ALL parameters

- Lock jumper must be set to unlocked, refer to **Step 9**
- Parameter Access Code must be correct, see **Step 12**
 - Control access code comes factory preset at 0
 - If you have customized the control access code, you will need to enter it for access

To allow access (unlock) to ONLY the SP, Set Point, parameter

- Lock jumper must be set to unlocked, refer to **Step 9**
- Parameter Access Code must be customized and with any number from 1-99, see **Step 12**

To block access (lock) ALL parameters

- Lock jumper must be set to locked, refer to **Step 9**

11

ENTERING PARAMETER ACCESS CODE TO UNLOCK ALL PARAMETERS

- Press SET for 8 seconds.
The access code value 0 is shown on the display.

If this is initial setup or if you chose to keep the factory set code of 0

- Press SET to confirm 0 as the code.
 - The first parameter reference, SP (Set Point), will be shown on the display.

If you have already customized the H5 Parameter Access Code

- Use the UP and DOWN keys to increase the number to match your custom code, then press SET to confirm code.
 - The first parameter reference, SP (Set Point), will be shown on the display.

If you have customized the H5 Parameter Access Code but cannot remember the chosen code, you can reset the Parameter Access Code to the factory set code of 0.

- Press and hold the SET key and cycle power to the control.

NOTE: Once you have unlocked the parameters 1 minute of inactivity will timeout the unlock and the access code will again need to be entered to resume programming.

12

CUSTOMIZING PARAMETERS

Once parameters are unlocked they can be customized

- Using the UP and DOWN keys, move to the desired parameter you wish to customize.
- Press SET to see the value of the parameter.
- Modify the value with the UP and DOWN keys.
- Press SET to save the new value and return to parameter list.
- Press SET and DOWN to quit programming, or wait 1 minute for TIMEOUT.

13

PARAMETER LIST & DESCRIPTIONS

	Description	Range
SP	Set Point Temperature desired to regulate the unit	r1 to r2
r0	Differential or Hysteresis Heating: If temperature is \geq SP then output is OFF If temperature is $<$ SP – r0 then output is ON Cooling: If temperature is \geq SP + r0 then output is ON If temperature is $<$ SP then output is OFF	1 to 20°
r1	Lower Set Point Limit	-50 to 302°F -50 to 150°C
r2	Upper Set Point Limit	-50 to 302°F -50 to 150°C
d0	Heating or Cooling Control Ht = Heating Control Co = Cooling Control	Ht / Co
d2	Defrosting Time Remaining If d2 = 0, defrosting will not start	0 to 59 Minutes
d8	Interval Between Two Defrostings	0 to 24 Hours
c0	Minimum Time for Compressor to be OFF Minimum time for compressor to stop until it can start again.	0 to 59 Minutes
c1	Continuous Cycle Time The remaining time for a continuous cold cycle.	0 to 24 Hours
c2	ON Time of fault cycle, during probe error	0 to 999 Minutes
c3	OFF Time of fault cycle, during probe error	0 to 999 Minutes
P0	Temperature Units Selection	°C/°F
P1	Ambient Probe Calibration If extending probe beyond 10' measure temperature and adjust probe calibration	-10 to 10°
H5	Parameter access code (Factory set to 0)	0 to 99
H6	Selection of Input Probe Type	NTC
t0	Temperature Display Limit Maximum temperature shown on the display, although the real temperature can be greater.	-50 to 302°F -50 to 150°C

INDICATORS & ERROR MESSAGES

Indicators

 This indicates that the output is energized or that the compressor is connected. It waits for the programmed minimum stop time of the compressor.

 This indicates that defrosting is activated.

Error Messages

In normal operation, the probe temperature will be shown. In case of alarm or error, the following messages will be shown:

- Er- Memory error
- -- Shorted-circuited probe error
- oo- Open probe error

NOTE: If the probe or thermostat memory should fail, the compressor will be connected in accordance to the parameters set in C2 and C3.

MAINTENANCE

After final installation of the JDDT1 Digital Temperature Switch, no routine maintenance is required. A periodic check of system calibration is recommended.